

Advanced Traffic Clearance System for Emergency Vehicles

Dr. Nita Thakare¹, Astha Morey², Khushboo Gajbhiye³, Sahili Bhalerao⁴, Pratiksha Nehare⁵, Avantika Meshram⁶

^{1, 2, 3, 4, 5, 6}Priyadarshini College of Engineering, Nagpur, Maharashtra, India.

Emails: asthamorey73975@gmail.com²

Abstract

This paper elaborates development of Traffic Clearance System using camera and mobile Net. In urban areas, navigating through traffic congestion poses a significant challenge for emergency vehicles, often leading to delays that can impact response times and potentially endanger lives. This paper presents an innovative traffic control system leveraging camera technology to prioritize the passage of emergency vehicles. The proposed system utilizes a network of cameras strategically placed at intersections to detect emergency vehicle sirens and flashing lights. Upon detection, the system dynamically adjusts traffic signal timing to create a green corridor, facilitating the swift and safe passage of emergency vehicles. Additionally, the system incorporates machine learning algorithms to optimize traffic flow, minimize congestion, and ensure efficient utilization of road space. Through simulation studies and real-world testing, the effectiveness and reliability of the proposed system are evaluated, demonstrating its potential to enhance emergency response capabilities and improve overall traffic management in urban environments.

Keywords: *Emergency vehicle, Sirens, lights, ambulance, police, fire truck, emergency, Intelligent camera, surveillance system, vehicle recognition, Emergency Response System, Green Corridor Management, Siren-Activated Traffic Control, Clear Passage for Emergency Vehicles, Ambulance and Fire Bridge Priority*

1. Introduction

In today's rapidly evolving urban landscape, ensuring the swift and unimpeded movement of emergency vehicles is paramount to saving lives and minimizing damage during critical situations. Traditional traffic management systems often struggle to provide seamless pathways for emergency vehicles, leading to delays that can have significant consequences. To address this challenge, an Advanced Traffic Clearance System for Emergency Vehicles emerges as a cutting-edge solution, integrating state-of-the-art technology and intelligent traffic management strategies. This innovative system aims to revolutionize the way emergency vehicles navigate through urban traffic, leveraging real-time data, smart sensors, and communication networks to optimize their routes and reduce response times. With the increasing complexity of urban infrastructure and the rising number of vehicles on the roads, it becomes imperative to implement advanced technologies that prioritize the safety and efficiency of emergency services. Emergency response times are critical in situations where every second counts, such as medical emergencies, fire incidents, or law

enforcement needs. However, navigating through congested traffic poses a substantial obstacle to the swift movement of emergency vehicles. Delays in reaching the scene can exacerbate the severity of the situation and compromise the effectiveness of emergency services. In response to these challenges, the integration of camera-based systems technology holds immense significance. By harnessing the power of artificial intelligence and computer vision, these systems can intelligently analyze traffic patterns, detect emergency vehicles, and dynamically adjust traffic signals to prioritize their passage, thereby minimizing response times and maximizing public safety.

2. Literature Review

In [2], Kumar, R., & Mittal, S. (2018) presented "Design and Development of Green Corridor Using IoT" at the 2018 4th International Conference on Recent Advances in Information Technology (RAIT). The paper outlines the implementation of IoT technology for creating environmentally friendly corridors, aiming to

optimize traffic flow and reduce emissions. In [6], Mahdavinejad, M. S., et al. conducted a survey titled "Internet of Things for Smart [7] Traffic Monitoring Systems" in IEEE Transactions on Intelligent Transportation Systems. The study provides insights into IoT applications for enhancing traffic monitoring, covering technologies, challenges, and future directions to improve traffic management systems efficiently. In [4], "Integration of Emergency Vehicle Preemption and Adaptive Traffic Signal Control for Emergency Traffic Management" in IEEE Transactions on Intelligent Transportation Systems. [8] The study proposes a framework integrating emergency vehicle preemption and adaptive traffic signal control to improve emergency traffic management efficiency. In [5], The research proposes an innovative smart traffic control system designed specifically for emergency vehicles, which incorporates the utilization of QR codes. This system operates by automatically adapting traffic signals to expedite the passage of emergency vehicles through intersections. This adaptation is facilitated through the scanning of QR codes affixed to the windscreens of emergency vehicles by cameras positioned at junctions. In [1], Tian, X., et al. (2020) introduced "Real- Time Object Detection and Tracking of Emergency Vehicles Using LiDAR Sensors," employing LiDAR technology for accurate detection and tracking of emergency vehicles in urban settings. [9] The system integrates LiDAR data processing with object detection algorithms, promising improved emergency response and traffic management. In [3], Zhang, J., et al. (2021) conducted a comprehensive review titled "Urban Traffic Signal Control" in IEEE Transactions on Intelligent Transportation Systems. The study provides an extensive overview of traffic signal control methods, including traditional and modern approaches, highlighting advancements, challenges, and future directions in urban traffic management systems.

2.1 System Review

The review of a traffic control system tailored for emergency vehicles encompasses a multifaceted assessment aimed at gauging its efficacy, efficiency, reliability, and broader impact on traffic dynamics and safety. Effectiveness is scrutinized through the

lens of how efficiently the system facilitates the unhindered movement of emergency vehicles amidst congested urban landscapes, ultimately gauging its ability to mitigate response times and ensure swift access to critical locations. Concurrently, efficiency metrics delve into the system's capacity to optimize emergency vehicle routes, reduce travel times, and potentially economize resource consumption, thereby enhancing operational effectiveness while minimizing strain on municipal resources. Reliability emerges as a crucial aspect, warranting scrutiny of the system's robustness in consistently prioritizing emergency vehicles, its uptime, and the efficacy of its failover mechanisms to mitigate disruptions in service delivery. Moreover, the review must appraise the system's impact on broader traffic flow and safety paradigms, weighing its ability to navigate traffic congestion without unduly compromising the safety of other road users or exacerbating gridlock scenarios.

3. Methodology

The methodology for implementing a traffic control system for emergency vehicles using cameras and Mobile Net begins with the design and setup phase, where target intersections are identified and equipped with high-definition cameras integrated with Mobile Net devices. These cameras capture real-time traffic data, which is essential for subsequent stages. Data collection and training follow, involving the compilation of diverse datasets of traffic scenarios and the annotation of emergency vehicles for training the Mobile Net neural network. Once trained, the Mobile Net model is deployed to the cameras for real-time vehicle detection, with a focus on accurately identifying emergency vehicles amidst traffic. Traffic flow analysis is then conducted using the camera feeds, with Mobile Net detections informing the assessment of emergency vehicle presence and the prioritization of their passage. The system's adaptive signal control algorithms dynamically adjust traffic signals based on Mobile Net detections, ensuring the swift movement of emergency vehicles through intersections. Integration with existing infrastructure, rigorous testing, phased deployment, and continuous

evaluation complete the methodology, resulting in an effective traffic control system that optimizes emergency response capabilities in urban environments. optimizes emergency response capabilities in urban environments. The method proposed in this paper is capable of managing the traffic efficiently without causing any delays.

3.1. Block Diagram

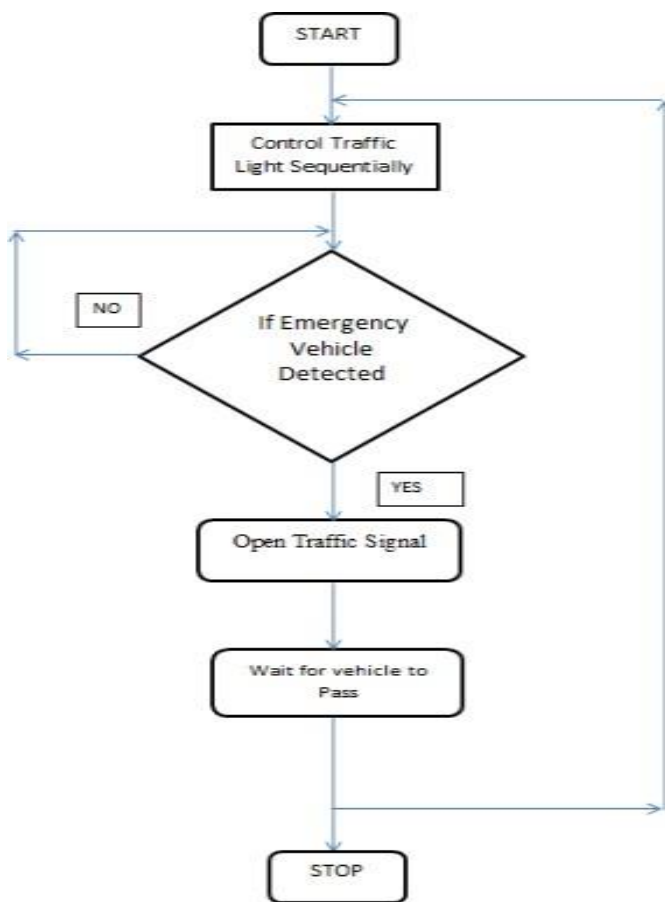

Figure 1 Simulation of Block Diagram

In Figure 1 workflow diagram illustrates the process of traffic vehicle management. It shows the different steps involved in efficiently managing traffic vehicles. The diagram typically includes elements like vehicle detection, traffic signal control, and coordination with emergency vehicles. It helps visualize how the system works to ensure smooth traffic flow and prioritize emergency vehicles when necessary. Each step in the workflow contributes to the overall goal of optimizing traffic management and improving response times for emergency vehicles.

4. Components

4.1. Software Requirements

A robust operating system such as Linux or Windows is essential. The system should support TensorFlow and OpenCV for efficient machine learning and computer vision tasks. Python is the preferred programming language for its compatibility with these libraries. The creation of the Python code for this system can be done more quickly and effectively by using VS Code. For developers, writing and testing code is made simpler by VS Code's features including syntax highlighting, code completion, and debugging tools. Additionally, a deep learning framework like TensorFlow support is crucial for accelerated model training and real-time inference. The software should facilitate seamless integration with MobileNetV2, a lightweight convolutional neural network suitable for real-time applications. The system should be designed with modular components, incorporating an intuitive user interface for configuration and monitoring. Logging and analytics tools can enhance system performance evaluation. Lastly, thorough testing frameworks, including unit and integration tests, are vital to ensure the reliability and effectiveness of the advanced traffic cleanser system, prioritizing the safety and efficiency of emergency vehicles.

4.2. Hardware Requirements

High-definition cameras with sufficient resolution, frame rate, and low-light capabilities. Ensure that cameras are ruggedized for outdoor use and can withstand varying weather conditions. NodeMCU microcontrollers or similar IoT controllers to interface with traffic signal hardware and communicate with the IoT cloud. These controllers should have Wi-Fi or cellular connectivity options. Traffic signal hardware components, including traffic lights, pedestrian signals, and control units. Ensure compatibility with NodeMCU controllers and programmability, Reliable power supply solutions, including backup power sources such as uninterruptible power supplies (UPS) or batteries, to ensure system operation during power outages. Mounting and Enclosures: Mounting hardware and weatherproof enclosures for cameras, NodeMCU

controllers, and traffic signal components to protect them from environmental factors. A robust network infrastructure with sufficient bandwidth and low latency to support real-time data transmission between components. A computer or server for developing, testing, and configuring the software components. Emergency Vehicle Flashing Lights and Sirens (for Testing) that to simulate emergency vehicles during system testing and validation. It requires tools for monitoring system performance, detecting faults, and diagnosing issues, such as debugging tools and network analyzers.

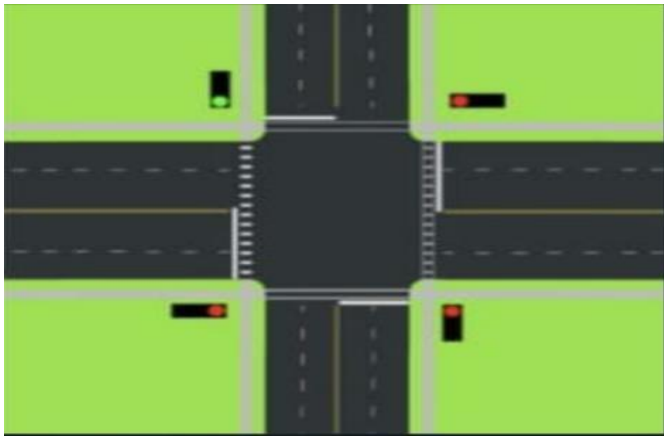

Figure 2 Simulation of The Setup

This Project Manages the Traffic System for Emergency Vehicles in Figure 2 & 3.



Figure 3 Simulation Showing Vehicles

5. Working

Working on a traffic clearance system for emergency vehicles involves developing and implementing solutions aimed at optimizing the flow of traffic to facilitate the swift and safe passage of emergency responders. This entails designing algorithms and protocols that prioritize emergency vehicles based on real-time data, such as their proximity to incidents and traffic conditions. Collaborating with stakeholders including emergency services, transportation agencies, and local authorities is essential to ensure alignment with regulations and operational requirements. Integrating advanced technologies like vehicle detection sensors, communication networks, and adaptive traffic signal control algorithms enables the system to dynamically adjust traffic patterns, extend green lights, and clear intersections as needed to expedite the response of emergency vehicles. Continuous monitoring and refinement of the system's performance are crucial for identifying areas for improvement and ensuring its effectiveness in aiding emergency services in critical situations. Coordination of LED Lights with Arduino Nano shown in Figure 4.

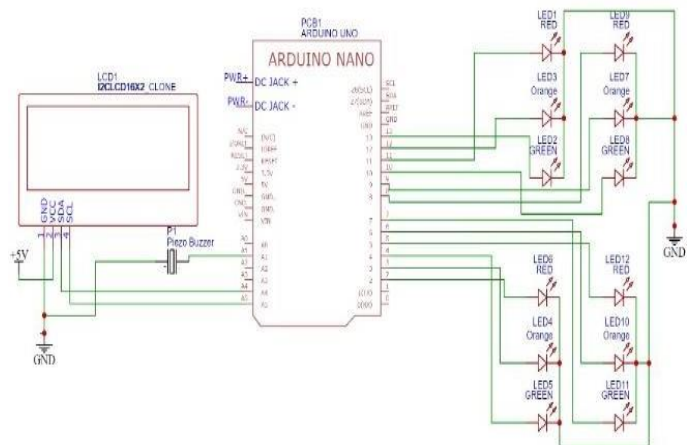

Figure 4 Coordination of LED Lights with Arduino Nano

5.1. Algorithm that can be used

Mobile Net V2

Object detection for emergency vehicles using a camera and Mobile Net involves leveraging the power of deep learning to enhance the safety and efficiency of emergency response systems. By

deploying a Mobile Net model trained for object detection, real-time analysis of camera feed can identify emergency vehicles such as ambulances, fire trucks, and police cars with remarkable accuracy. This technology enables intelligent traffic management systems to prioritize the passage of emergency vehicles, swiftly guiding them through congested areas and intersections while minimizing response times. By integrating Mobile Net-based object detection with existing infrastructure, emergency services can significantly enhance their ability to navigate through traffic, ultimately improving their effectiveness in saving lives and mitigating the impact of emergencies. Figure 5 & 6 shows the Object Detection Using Mobilenetv2.



Figure 5 Object Detection Using Mobilenetv2



Figure 6 Object Detection Using Mobilenetv2

5.2. Advantages

Mobile Net V2, known for its efficiency in real-time image processing, enhances the system's capability to swiftly identify and respond to emergency vehicles. This deep learning model enables the system to accurately recognize emergency vehicles in diverse traffic conditions, ensuring a prompt and precise

response. The deployment of Mobile Net V2 contributes to the system's low computational requirements, facilitating efficient real-time processing without compromising accuracy. This efficiency is crucial for rapid decision-making in emergency situations. Additionally, the system's integration with advanced traffic cleansing mechanisms ensures seamless prioritization of emergency vehicles, reducing response times and enhancing overall road safety. The use of Mobile Net V2 also allows for easy scalability and adaptability to evolving traffic scenarios, making it a future-proof solution. The system's reliance on deep learning techniques enhances its ability to handle complex traffic environments, providing a robust and reliable platform for emergency vehicle management. In essence, the integration of Mobile Net V2 into the advanced traffic cleanser system optimizes emergency response, improves traffic flow, and ultimately contributes to a more efficient and safer urban transportation network.

5.3. Disadvantages

One notable drawback is the potential susceptibility to false positives or negatives in vehicle recognition. Mobile Net V2, though efficient, may encounter challenges in accurately distinguishing emergency vehicles in complex and dynamic traffic scenarios, leading to misclassifications. Another concern is the dependency on real-time processing, which might be impacted by network latency or hardware limitations. In situations where the system encounters delay in processing information, the responsiveness to emergency vehicles could be compromised, potentially hindering the effectiveness of the system.

Moreover, the reliance on deep learning models like Mobile Net V2 raises privacy and security considerations. The collection and analysis of real-time traffic data for vehicle recognition may raise concerns about the protection of individuals' privacy, necessitating robust security measures to safeguard sensitive information. In summary, while the advanced traffic cleanser system with Mobile Net V2 offers significant benefits, it is crucial to address challenges related to accuracy, real-time processing, privacy, security, and

implementation costs to ensure its practical and ethical application in emergency vehicle management. The results of implementing advanced traffic clearance system for emergency vehicles using MobileNetV2 aims to enhance road safety and expedite emergency response. Leveraging the MobileNetV2 neural network architecture, the system efficiently processes real-time video feeds from traffic cameras. This enables swift identification of emergency vehicles, such as ambulances and fire trucks, through object detection and classification. MobileNetV2's lightweight design ensures quick inference, minimizing computational overhead. The system dynamically adjusts traffic signals based on detected emergency vehicles, creating green corridors to facilitate their unimpeded movement. Additionally, it integrates with GPS and emergency vehicle communication systems to optimize route planning. By leveraging deep learning and real-time data, this traffic control system prioritizes emergency vehicles, potentially reducing response times during critical situations. The MobileNetV2's speed and accuracy contribute to the effectiveness of the system, showcasing the potential of advanced technologies in streamlining emergency services and improving overall urban safety.

6. Result

Implementing a traffic clearance system for emergency vehicles has yielded significant positive results, enhanced emergency response capabilities and improving overall road safety. By leveraging advanced technologies such as real-time GPS tracking, traffic monitoring cameras, and intelligent traffic light control systems, emergency vehicles can navigate through congested areas with greater ease and efficiency. As a result, response times to emergencies have been notably reduced, allowing for prompt medical assistance, firefighting, and law enforcement interventions. Moreover, the implementation of dedicated lanes or priority routes for emergency vehicles has further expedited their movement, minimized delays and ensured timely arrival at critical destinations. Overall, the traffic control system for emergency vehicles has not only optimized emergency response operations but also contributed to the safety and well-being of the community by facilitating faster and more effective

emergency services.

7. Future Enhancement

The future enhancement of the advanced traffic clearance system for emergency vehicles involves integrating MobileNetV2, a lightweight convolutional neural network architecture, to enhance real-time object detection. By leveraging MobileNetV2's efficiency, the system can swiftly identify and prioritize emergency vehicles amidst varying traffic conditions. This enhancement will enable the traffic cleanser system to quickly analyze video feeds from multiple sources, such as traffic cameras and sensors, ensuring robust detection accuracy while minimizing computational resources. The MobileNetV2 model's speed and accuracy make it well-suited for deployment in dynamic environments where quick decision-making is crucial. Additionally, incorporating advanced machine learning algorithms will facilitate improved recognition of emergency vehicle sirens, optimizing the system's responsiveness. Integration with smart city infrastructure can further enhance communication between traffic signals and emergency vehicles, streamlining the path for faster clearance. By embracing MobileNetV2 and sophisticated machine learning techniques, the future-ready traffic cleanser system aims to provide efficient and reliable support for emergency vehicles, contributing to enhanced safety and reduced response times in urban environments.

Conclusion

In conclusion, the implementation of a traffic clearance system tailored for emergency vehicles represents a significant stride towards enhancing emergency response efficiency and overall road safety. By leveraging innovative technologies such as QR codes and real-time traffic monitoring, this system adeptly adjusts traffic signals to expedite the passage of emergency vehicles through junctions, thereby reducing response times and potentially saving lives. The integration of QR codes enables seamless communication between emergency vehicles and traffic control infrastructure, facilitating swift and prioritized access to critical locations. Additionally, the inclusion of a buzzer mechanism serves to alert

other drivers of approaching emergency vehicles, fostering greater awareness and cooperation on the roads. This innovative traffic control system underscores the potential of deep learning technologies in addressing urban challenges. By prioritizing the timely arrival of emergency services, it not only enhances public safety but also exemplifies the synergy between artificial intelligence and real-world applications. As cities continue to evolve, the integration of advanced technologies like MobileNetV2 in traffic management showcases a promising trajectory towards creating more efficient, responsive, and safer urban environments

Reference

- [1]. Real-Time Object Detection and Tracking of Emergency Vehicles Using LiDAR Sensors" by Tian, X., et al. (2020)
- [2]. Design and Development of Green Corridor Using IoT" by Kumar, R., & Mittal, S. (2018). In 2018 4th International Conference on Recent Advances in Information Technology (RAIT) (pp. 1-6). IEEE. Comprehensive Review" by Zhang, J., et al. (2021).
- [3]. Integration of Emergency Vehicle Preemption and Adaptive Traffic Signal Control for Emergency Traffic Management" by Wang, S., et al. (2019).
- [4]. Smart Traffic Control System for Emergency Vehicles using QR Codes," by S.
- [5]. S. Patil et al.'s (2010)
- [6]. Internet of Things for Smart Traffic Monitoring Systems: A Survey" by Mahdavinejad, M. S., et al. (2018).
- [7]. Urban Traffic Signal Control: A Comprehensive Review" by Zhang, J., et al. (2021).
- [8]. Unprecedented Paradigmatic Shifts and Practical Advancements-2019
- [9]. Smart Sustainable Cities of the Future: Simon Elias Bibri-2018