

Smart Parking System using IOT with Blynk and RFID

Vignesh N¹, Manoj M², Suhaas P Reddy³, Koushik Reddy⁴

^{1,2,3,4} Student, Department of Computer Science and Engineering, Dayananda Sagar College of Engineering, Bengaluru, Karnataka, India.

Emails: vigneshrage@gmail.com¹, manuappu738@gmail.com², suhaasreddy2002@gmail.com³, katakamkoushik2003@gmail.com⁴

Abstract

This project presents a Smart Parking System tailored to address the unique parking challenges of organizations and restricted-access entities. It integrates Infrared (IR) sensors, Radio-Frequency Identification (RFID) tags, and Cloud connectivity. IR sensors monitor parking space occupancy in real-time, while RFID tags serve as secure physical credentials for authorized personnel, enhancing access control. The system incorporates a Blynk app for authorized users to access real-time parking data, check availability, and helps users make informed decisions about parking. This app acts as a centralized hub for efficient parking management, improving the overall parking experience. Architecturally, the system utilizes a centralized control unit controlling interactions between IR sensors, RFID authentication, and the Blynk cloud server. This approach allows only authorized users to access the parking lot, resulting in a scalable and adaptable solution prioritizing exclusivity, efficiency, convenience, and security in parking management for specialized environments.

Keywords: Blynk App, IOT, RFID, Smart Parking Systems.

1. Introduction

With urbanization on the rise, the challenge of efficient parking management has become more important than ever. Traditional parking setups often lead to congestion, wasted time, and increased environmental impact. Smart Parking Systems emerge as a solution to these challenges, offering real-time monitoring and streamlined access. This introduction explores the necessity for Smart Parking Systems and how the integration of Infrared (IR) sensors, Radio-Frequency Identification (RFID) tags [1], and the Blynk mobile application [2] can revolutionize parking, providing a seamless and intelligent solution for modern urban environments. Conventional parking infrastructure is plagued by inefficiencies, causing frustration for drivers and contributing to increased traffic congestion. Smart Parking Systems are crucial for transforming this landscape, offering real-time monitoring and secure access control. These systems not only alleviate the stress of parking but also contribute to a more sustainable and organized urban environment. Integrating Infrared (IR) sensors, Radio-Frequency

Identification (RFID) tags, and the Blynk mobile application addresses the shortcomings of traditional parking systems. IR sensors provide real-time occupancy data, RFID tags ensure secure identification, and the Blynk app acts as an intuitive interface for users to check availability of parking slots and helps the users identify empty parking spots with real time data. Together, these components form a Smart Parking System that enhances user experience and improves parking management for a more connected and sustainable urban future.

2. Related Works

Smart Parking Systems are solutions designed to optimize the management of parking spaces, providing more efficient, user-friendly, and sustainable urban parking experiences. These systems leverage various technologies, including sensors, communication networks, and mobile applications, to address the challenges associated with traditional parking methods. Smart Parking Systems have emerged as a solution to address the challenges associated with traditional parking

management. Key findings from recent studies have been included in this survey, highlighting the benefits and advancements offered by smart parking technologies. In the survey conducted, it was found that there have been many proposals for a smart parking system. IR Sensors have been extensively used for the detection of vehicles present in the parking slots. In Smart Parking Systems, Infrared (IR) sensors emerge as a highly effective solution due to their real-time occupancy detection, accuracy, and cost-effectiveness. These sensors are equipped with photocells tuned to detect infrared light and offer information about parking space availability, ensuring accurate and reliable data for users. A paper noted that IR sensors are notably used for remote control detection, IR sensors exhibit low power consumption, as evident in electronic devices such as TVs and DVD players [3]. Another paper noted their ease of integration, durability, and applicability to diverse parking configurations make them a practical choice for smart parking infrastructure, aligning with the key requirements of scalability and efficient parking management [4]. As a result, IR sensors contribute significantly to optimizing parking space utilization and enhancing the overall user experience in smart parking environments. In a paper published in 2016 [5], it was found that smart parking systems that utilize IR sensors are the most common and standardized method of utilizing smart parking systems. RFID tags have also been used for Smart Parking Systems for the purpose of authentication. A paper delves into the Radio Frequency Identification (RFID) tags and its libraries [6]. The operation of RFID tags involves the tag, antenna, and coupler. The antenna creates a magnetic field around it. Whenever the tag enters the RF field, the antenna's RF signal activates the tag. The coupler sends a modulated signal. The tag demodulates the signal and then returns its data to the computer. The computer sends new data through the coupler to the tag. Different applications of RFID in various fields are discussed in this paper. Another paper [7] provides a comprehensive examination of Radio-Frequency Identification (RFID) technology and its diverse applications. The paper begins by offering a detailed explanation of RFID technology, explaining its core

principles, components. They discuss RFID's role in supply chain management, healthcare, retail, and transportation, emphasizing its capacity to enhance efficiency, accuracy, and traceability in diverse operational contexts. The authors draw attention to RFID's ability to revolutionize inventory management, streamline logistics, and improve patient care in the healthcare sector. Blynk is a versatile and user-friendly Internet of Things (IoT) platform that allows individuals, developers, and businesses to build custom applications for controlling and monitoring connected devices. The Blynk app is a central component of this platform, providing a visual interface through which users can create customizable dashboards for their IoT projects. The app is available for both iOS and Android devices. With the Blynk app, users can design interactive and responsive graphical interfaces, known as Blynk apps or dashboards, by dragging and dropping widgets. These widgets include buttons, sliders, graphs, displays, and more, each corresponding to specific functionalities or data points in the connected devices. The app facilitates real-time communication with IoT hardware using a variety of connectivity options, including Wi-Fi, Ethernet, Bluetooth, and cellular networks. A paper [8] dives into the use of Blynk framework for IOT systems. The primary focus of the paper is to create an IOT based smart home using the Blynk framework. They use many sensors like HC -SR04 to detect the water level in the tank, and pump water whenever the water level is below a certain level, a PIR sensor that detects motion of humans, then opens the door automatically when it detects motion, a temperature sensor that detects the ambient temperature in each room and then turns on the fan whenever it detects that the temperature has gone above a certain temperature. All these readings and data has been integrated into the Blynk app. The dashboard shows the real time data and also offers the options to toggle the actuators for each actuator. A paper from 2020 [9] proposes a system that utilizes IoT (Internet of Things) technology and IR (Infrared) sensors for managing car parking. The system aims to develop a Car Parking Management System that utilizes IoT technology to display the availability of

parking slots. IR sensors are used in the system to detect the presence or absence of a car in a parking slot. [10] The system utilizes an LCD screen to display the vacant parking slots in real-time. The implementation of the system using Arduino, IR sensors, and ESP8266 [11] Wi-Fi module with Blynk integration is discussed, highlighting its efficiency in managing car parking by providing real-time information about available parking slots.

3. Implementation

3.1. Hardware Components Used

1. ESP8266
2. IR Sensor (LM393)
3. Servo motor (MG995)

4. 16x2 LCD Display (LCD2004)
5. RFID Scanner (EM-18)
6. RFID Card
7. Breadboard
8. Connecting wires
9. Power Source (Micro USB)
10. Mobile phone with Wi-Fi

3.2. Software Components Used

- Arduino IDE
- Blynk app on Play store or App store

3.3. System Architecture

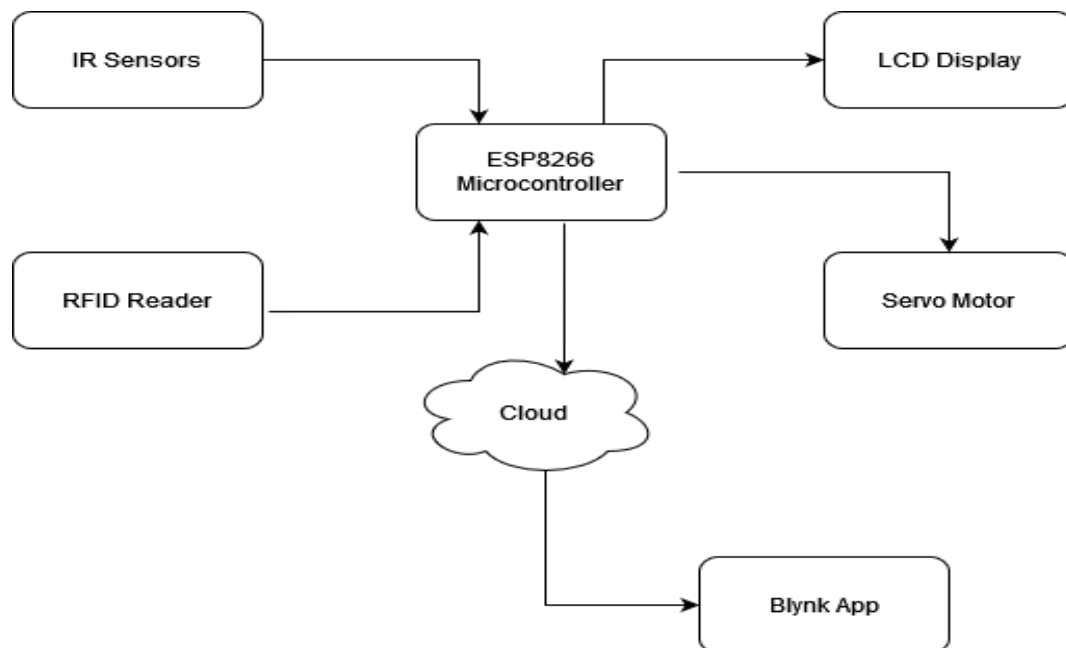

Figure 1 Block Diagram

Figure 1 shows the block diagram of the entire smart parking system, where the ESP8266 acts as the main control unit. [12] The Infrared (IR) sensors, Radio-Frequency Identification (RFID) scanner, LCD display, and the servo motor are all linked to the ESP8266. The IR sensors provide real-time data on parking space occupancy. The RFID scanner acts as a security control measure allowing only the authorized users to access the parking lot. The servo motor acts as a physical barrier that denies entry to unauthorized personnel. The LCD display shows the

real time parking data to the users. The Blynk app is cloud based IOT platform, it shows the real time parking data virtually through the mobile app or the website, and the users can either view the parking status on the mobile app or the website version of the app. Figure 2 shows the circuit diagram of the whole smart parking system. The Micro controller ESP8266 is mounted onto a breadboard. The LCD display, servo motor, RFID scanner are all connected to the same breadboard on different gpio pins as seen in Figure 2.

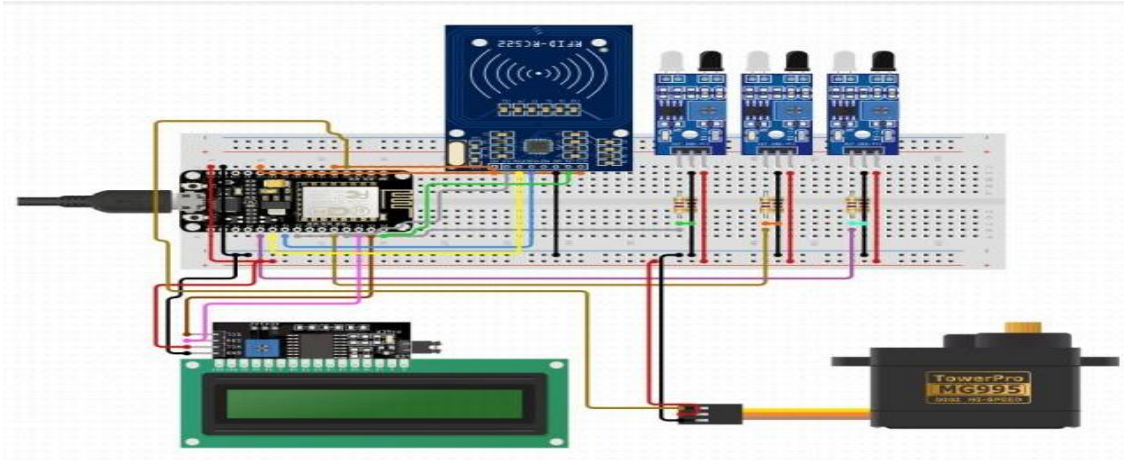

Figure 2 Circuit Diagram

The pins next to the green line are the ground pins, the pins next to the red wires are the live pins. The IR sensors are mounted separately on another breadboard which is in turn connected to the breadboard which has the ESP8266 mounted on it. This is done for the purpose of extending the length of the connection and allowing the IR sensors to be mounted on the parking spots.

3.4. Setup

Figure 3 shows the overall setup of the system. The breadboard containing the ESP8266 and all its connections is placed at 1 corner which is near the parking slot as well as the parking lot entrance.



Figure 4 Parking Slot with IR Sensors

The Breadboard containing the IR sensors is placed near the parking slots as seen in Figure 4.

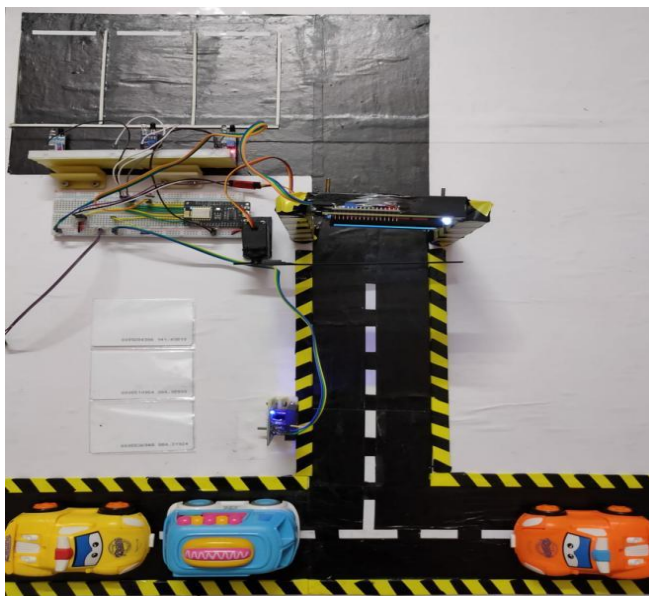

Figure 3 Overall Setup

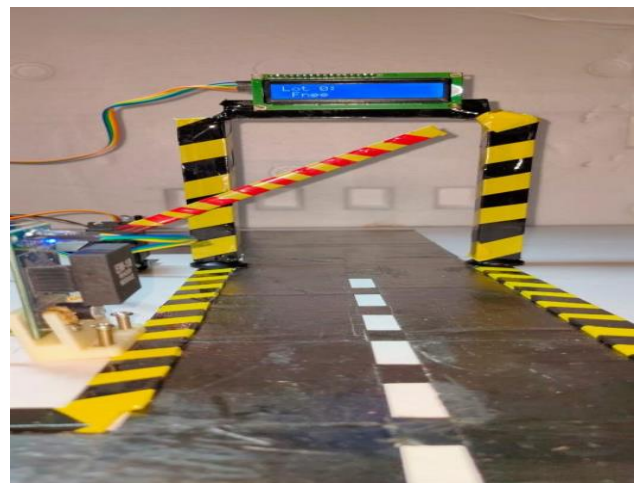

Figure 5 RFID scanner, LCD Display, Servo Motor at the gate

The RFID scanner, servo motor, LCD display are kept near the entrance of the parking lot as seen in Figure 5. The LCD display is mounted on an elevation for ease of visibility for users, the users can check the display to see if there are empty parking slots. The LCD display cycles through each parking slot. A bigger LCD display can be added to show all

parking slots concurrently. The servo motor is placed right in front of the entrance to the parking lot. This acts as a gate which allows only authorized users to enter the parking lot. The RFID scanner is mounted vertically at the entrance so that it is easier for users to place the RFID card and the gate opens while the user can remain in their vehicle.

3.5. Working

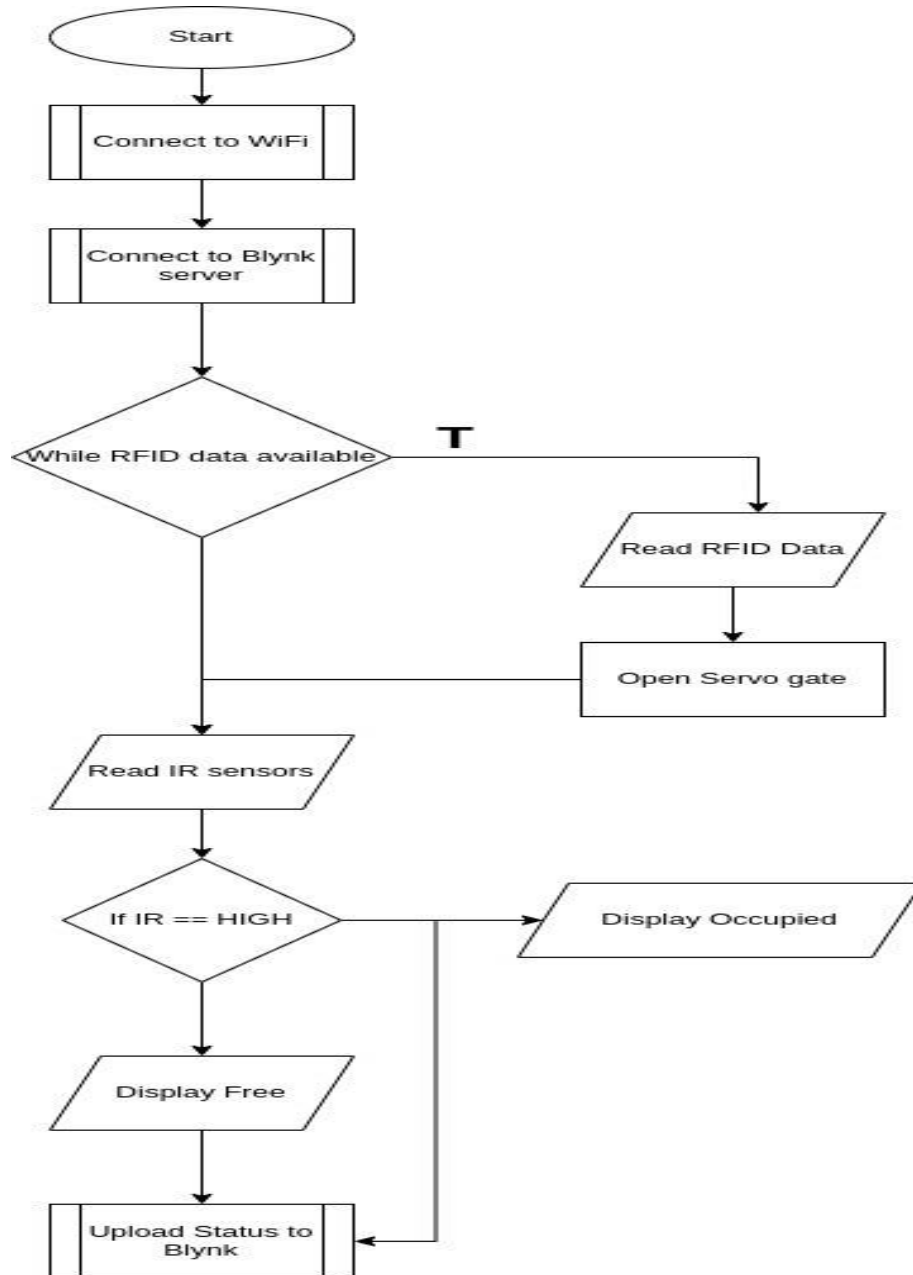

Figure 6 Flowchart

As seen in Figure 6, once the system is turned on, the system first connects to a WIFI signal for internet. After [14] connecting to the internet, the system is now online. The system then connects to the Blynk cloud server. The RFID scanner is always online as the RFID field is always active. Whenever an RFID card is placed near the RFID scanner, the signal is sent to the ES8266. The ESP8266 then sends another signal to the servo motor. [13] The servo motor then raises the barrier allowing the user to enter the parking lot. After a while the servo lowers the barrier. Whenever the IR sensors detect the presence of a vehicle, the status of that parking slot is changed from free to occupy. [15] Whenever the IR sensor detects the absence of a vehicle, the status of that parking slot is changed from occupied to free.

4. Results



Figure 7 Slot Status on LCD Display

Whenever an authorized user approaches the entrance of the parking lot, they can view the status of each parking slot in the LCD display that is mounted at the top (Figure 7).

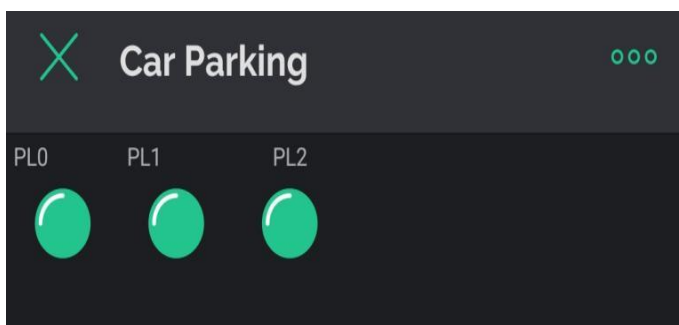

Figure 8 Slot Status on Blynk Mobile App

The user can also view the status of parking slots on the Blynk app on their mobile phone (Figure 8).

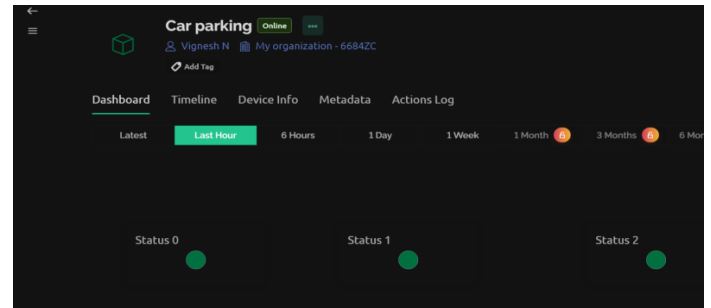

Figure 9 Parking slot status on Blynk Dashboard
 The user can also view the status on the web version of Blynk (Figure 9)



Figure 10 Gate is Closed

The gate is closed (servo motor barrier is lowered) by default (Figure 10) to prevent unauthorized access to parking lot.



Figure 11 Gate is Open

Whenever an authorized user with RFID tag places their RFID card near the RFID scanner, the gate is opened (servo motor barrier is raised) (Figure 11). After a while the gate is closed (the servo motor barrier is lowered) (Figure 10).

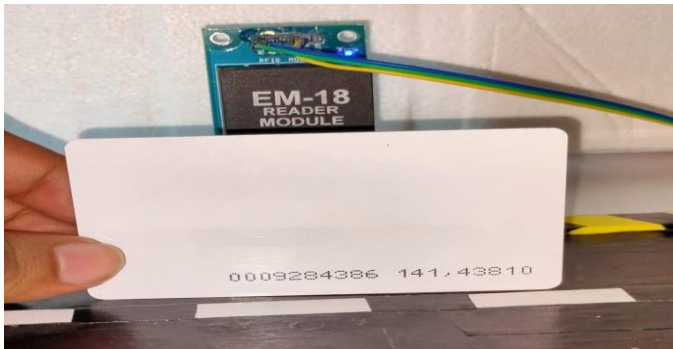

Figure 12 RFID Tag Kept Near the Scanner

The user can enter the parking lot after the barrier opens when they place the RFID card near the RFID scanner (Figure 12).

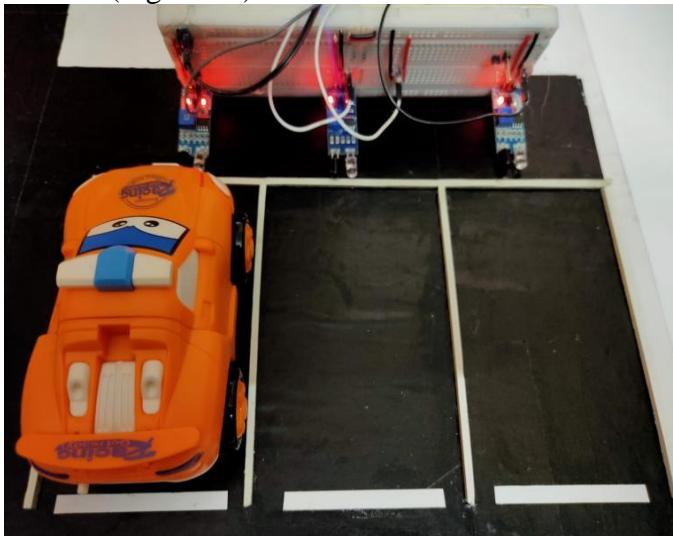

Figure 13 Parking Slot occupied

The user can park their vehicle in any of the empty parking spots (Figure 13). Once they park their vehicle in an empty parking slot, the IR sensor present at that parking slot will detect the presence of the vehicle and then send a signal to the ESP8266 which will then change the status of that parking slot from free to occupy.



Figure 14 Occupied on LCD Display

This change is displayed on both the LCD display at the entrance (Figure 14) and the Blynk app on mobile phone (Figure 15) and the dashboard on the web (Figure 16).

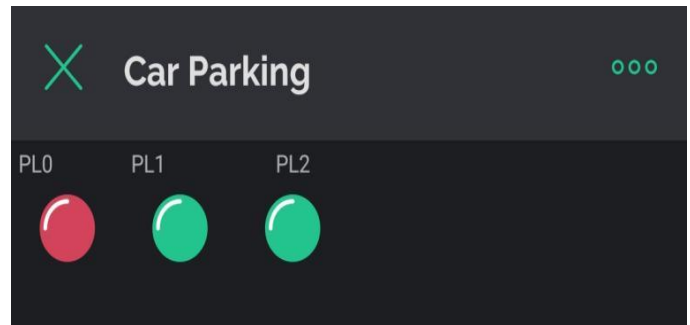

Figure 15 Occupied on Blynk Mobile App

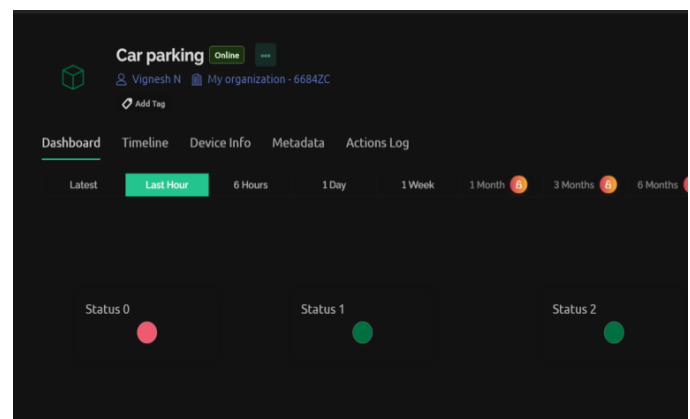

Figure 16 Occupied on Blynk Web Dashboard

Whenever the user wants to, the user can remove their vehicle from the parking slot and the IR sensor will detect the absence of the vehicle and send a signal to the ESP8266 which will in turn change the status of that parking slot from occupied to free on LCD and Blynk.

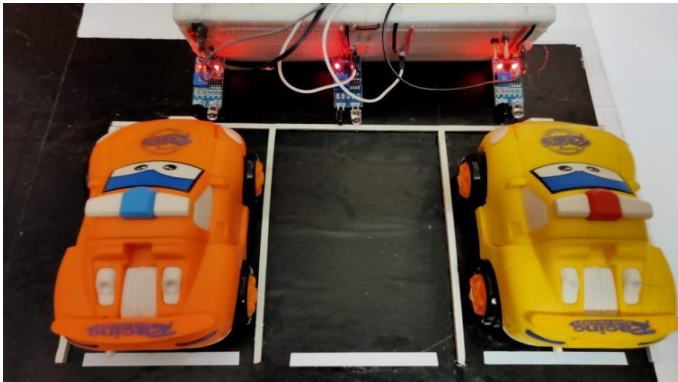

Figure 17 Multiple Cars Parked in Parking Slots

Whenever there are multiple cars parked in parking slots (Figure 17), correspond the parking status is shown as occupied and the status of rest is shown as free (Figure 18).

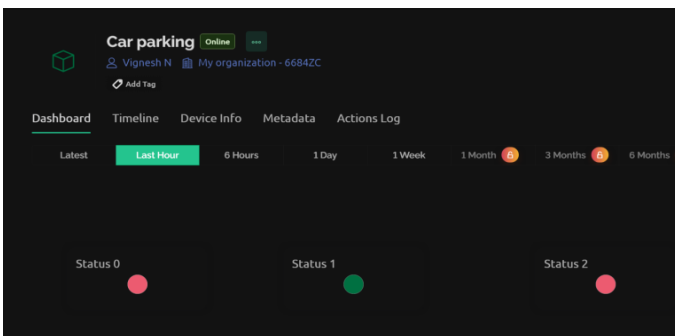

Figure 18 Multiple Parking Spots Occupied on Blynk Web Dashboard

Whenever all the parking slots are full, the LCD Display shows that the parking is full (Figure 19).



Figure 19 Parking Full on LCD Display

Conclusion

In conclusion, the smart parking system achieves its goal of combining IOT, Smart Parking, RFID technology and Blynk to create an intelligent, safe,

secure parking system for private organizations, private societies, and similar restricted-access entities. The system is secure as RFID scanners and tags allow only authorized personnel to access the parking lot. The system is Intelligent as it can detect the status of each parking slot. The system is safe as there are no security risks associated with it. The Smart parking system prioritizes user convenience, access time and real time status to provide a clever solution to the parking problem faced by private organizations, private societies, and similar restricted-access entities.

Future Enhancements

A robust notification system should be integrated to alert users, either through the Blynk app or SMS, whenever a parking slot becomes available. Collaborating with popular navigation apps will enable the provision of real-time directions to these available parking slots, ensuring a seamless journey from the entrance to the designated spot. Additionally, adapting a reservation model will empower users to reserve parking slots in advance. To streamline transactions, a payment gateway should be integrated to automate parking fee transactions. This system can charge users based on the duration of their parking session, with payments processed conveniently through the Blynk app. Artificial Intelligence features such as number plate scanning can be added for enhanced functionality. Moreover, advanced security features like biometrics should be implemented to ensure the safety and security of the parking system.

References

- [1]. Rfid Based Access Control System Using Arduino. Vivek Sharma, Vishal Singh, Vishal Kumar Mahar ,Shubham Naryani, Sourabh Kumawat,Assistant Professor, Electrical Engineering Department, SKIT Jaipur, India.
- [2]. Hands-On Internet of Things with Blynk by Pradeeka Seneviratne
- [3]. Yaqoob, I., Ahmed, E., Hashem, I. A. T., Ahmed, A. I. A., Gani, A., Imran, M., & Kim, B.-S. (2016). Internet of Things Architecture: Recent Advances, Taxonomy, Requirements, and Open Challenges. *IEEE Wireless Communications, 24*(3), 10-16.

- [4]. Al-Fuqaha, A., Guizani, M., Mohammadi, M., Aledhari, M., & Ayyash, M. (2015). Internet of Things: A Survey on Enabling Technologies, Protocols, and Applications. *IEEE Communications Surveys & Tutorials, 17*(4), 2347-2376.
- [5]. Shih, W.-Y., Chien, C.-F., & Chen, C.-Y. (2016). Smart Parking Systems: A Review of Relevant Technologies. *IEEE Transactions on Intelligent Transportation Systems, 17*(12), 3274-3286.
- [6]. Radio Frequency Identification (RFID): Its Usage and Libraries, By Muhammad Rafiq1, Librarian, National Textile University, Faisalabad, Pakistan
- [7]. THE RFID TECHNOLOGY AND ITS APPLICATIONS: A REVIEW by DAVINDER PARKASH, TWINKLE KUNDU & PREET KAUR, Haryana College of Technology & Management, Ambala Road, Kaithal 136027, India
- [8]. IoT Based Smart Home Using Blynk Framework by Bharat Bohara and Sunil Maharjan, Department of Mechanical Engineering, Kathmandu University, Dhulikhel, Nepal
- [9]. IoT based Car Parking Management System using IR Sensor by Muhamad Muzhafar Abd Kadir, Mohd Nizam Osman, and Nor Arzami Othman
- [10]. A Simple Smart Home Based On Iot Using Nodemcu And Blynk By Ahmed H.H Imam
- [11]. C Programming for Arduino by Julien Bayle Published by Packt Publishing Ltd. Livery Place 35 Livery Street Birmingham B3 2PB, UK. ISBN 978-1-84951-758-4
- [12]. Access Control Using Rfid And Arduno By A.Pavithra, M.Kalavathi, S.Keerthi, Sk.Sabirunnisa, Department Of Electronics And Communication Engineering Gokaraju Rangaraju Institute Of Engineering And Technology (Affiliated to Jawaharlal Nehru Technological University) Hyderabad 500 090, 2013
- [13]. A Smart, Efficient, and Reliable Parking Surveillance System With Edge Artificial Intelligence on IoT Devices by Ruimin Ke , Student Member, IEEE, Yifan Zhuang, Ziyuan Pu , and Yinhai Wang , Senior Member, IEEE
- [14]. Smart Parking System using IoT Technology by Prof. Denis Ashok (Ph.D) Department of Design & Automation Vellore Institute of Technology Vellore, India, Akshat Tiwari Department of Design & Automation Vellore Institute of Technology Vellore, India, Vipul Jirge Department of Design & Automation Vellore Institute of Technology Vellore, India
- [15]. Smart Parking System Based on Bluetooth Low Energy Beacons With Particle Filtering Andrew Mackey, Student Member, IEEE, Petros Spachos , Senior Member, IEEE, and Konstantinos N. Plataniotis, Fellow, IEEE